

The witness- archive by Kim Lien Desault

The witness- archive is a person who is giving a witnessing of the work of an artist .
The archive will be embodied by the memory of the person and could be materialised by any kind of support link to the work to witness about.
The witness is made for testifying of experiences that are difficult to document, most of the time if the work is ephemeral or not an object. The witness - archive is made for performances, or in situ unexpected experiences of the work.
There is the time factor which is embodied by a person who is memorizing a moment of work.
The witness will stay the archive after the end of the work, a reachable person who could be able to report of the past work.
Then the archive is not anymore a document but a person.

First application of this project : Specific witness - archive for Foam Lab/

The Foam Lab project is a collective form of lab in which a group of people are meeting during several times in 5 months to produce " foam" coming outside of individual project. I proposed to elaborate a process of archiving the foam with a witness principle. Here each participant will be a witness of each others work.
By binome dating one is following the work of the other.
At the end of the 5 months the participants will be a collective - witness of the lab. Which will construct a "foam-archive".
In this lab : 11 people will be witness of an artist participant.
A catalogue of witness will be print and could be contacted by the audience to meet the archive of each work.
Each archive has a different format considering the speciality of the witness.

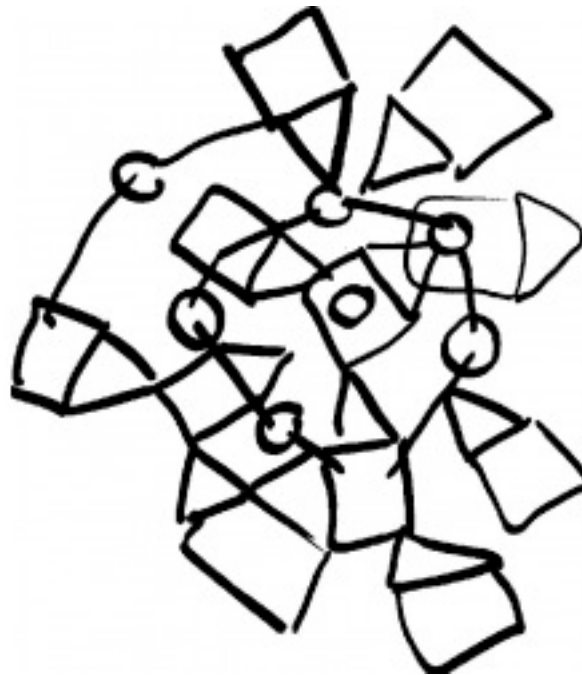

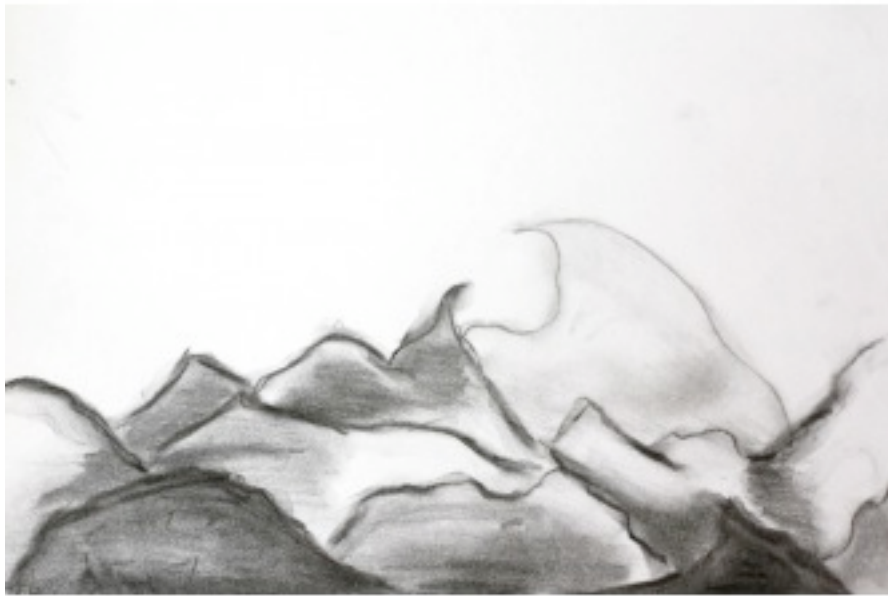

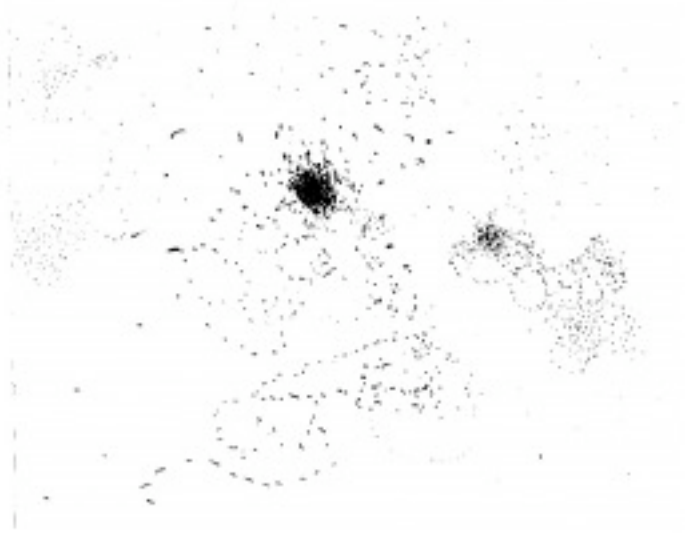

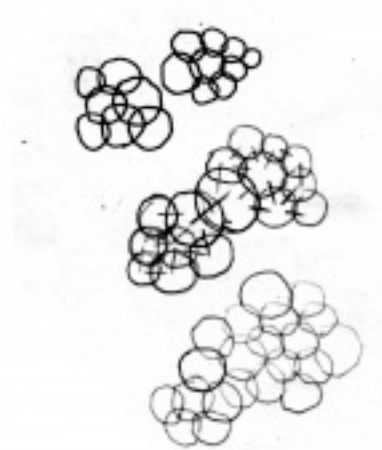
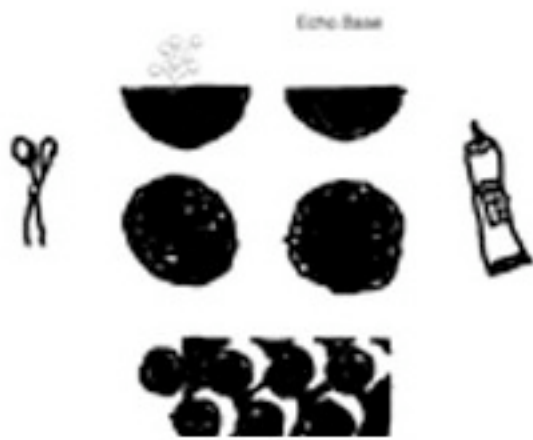

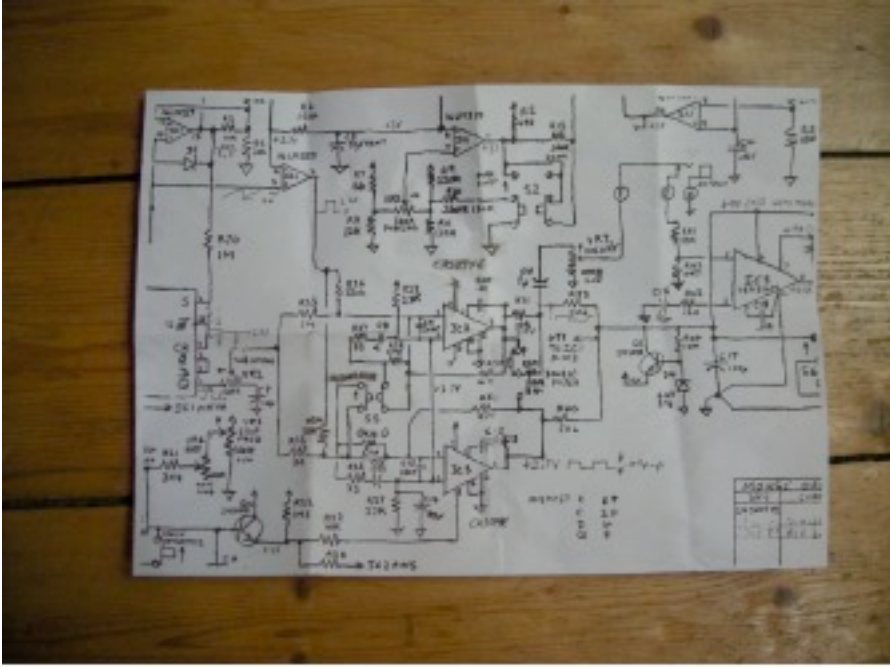

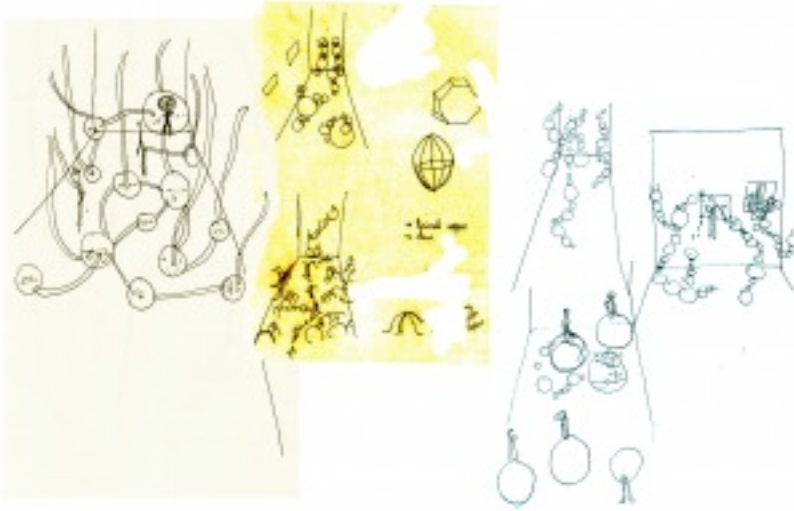

Drawings foam archive by : kim lien Desault, Florent Delval, Evelien Wouters, Eve Bonneau, Anne Dekerk, Michiel Reynaert, Sara Schelkens & Christoffel Hendricxx, Simon Williams, Monica Miranda, Maria Lucia.

Performance Showing :

Rules for the witness presentation:

please apply it very strictly....thanks

Hosting people :

- on the phone: when you receive a phone call, don't start any conversation details about the project...

Just say who you are witnessing, and give a date and a time.

- at echobase: you will get a key if the exhibit is not open at this time...
you will start to "perform" at the moment you host the guest.

Just a hello, and then you guide him with no words into the witness space.

- ending : until the ending of your performance no conversations are allowed between you and him: only your performance.

Talks are allowed only when you get out of the witness space.

The Witnessing:

- Your performance needs to have only one goal : to witness about another foam artist.

- The duration will depend on you (between 5 and 30mns)

- If you need to talk about the other artist you could use his surname or HE/SHE but never a "I" as if you are him /her.

- no other conversation are allowed because you are the performer, so the guest has to follow you.

If he tries to deviate just continue your action.

Practicalities :

- For any appointment contact me before, to set it up one last time by email or phone...

- Don't forget to plug the video camera to record the performance (so will prepare it before the appointment)

- Also at the bar of echo, there are tickets with some phone numbers, you could sometimes if you are around give it to the audience when they are in echo..

THANKS A LOT FOR YOUR COLLABORATION HAVE A GOOD ONE!!!

KIM

WITNESS - ARCHIVES PHONES

**MAKE AN APPOINTEMENT BY
PHONE FOR EACH
PERFORMANCE PLEASE!**

EVELIEN WOUTERS.....0486 414 273....

SARA SCHELKENS.....0496 984 557....

KIM LIEN DESAULT.....0496 789 464....

MICHIEL REYNAERT.....0479 430 458....

SIMON WILLIAMS.....0472 549 345....

FLORENT DELVAL.....0475 402 823....

MARIA LUCIA0487 604 539....

MONICA MIRANDA0479 856 435....

ANNE DEKERK0475 832 038....